



Electric Multi - Directional Sideloader L-Series / Longitudinal Seating



Technical Specifications

FIORA trucks employ the latest technology to ensure reliability and efficiency.

- Safety and security provided with an individual driver pin code provision necessary to start and operate the machine.
- Large sized cushion / poly / or SE tire options. Individual wheels located on the battery side and twin tires on the load side provide high ground clearance suitable for working indoors and outdoors. This stable platform reduces the average wheel pressure to 5.5 lbs/in²
- Two individual and balanced frames maintain the vehicles stability on uneven or slightly irregular floor surfaces. The wheels are kept in contact with the surface and evenly distribute the pressure.
- Low deck height for better space utilization at low levels.
- Mast sections are oversized and built with extruded manganese steel.
- High safety coefficients allow high residual capacities at the maximum elevation even with extended load centers.
- ~AC electronics and control unit management through open CAN-BUS architecture. High torque brushless ~AC motors optimize performance and reduce maintenance.
- Adjustment and customizing of speed and lift parameters.
- Energy recovery braking system improves the battery cycle and life expectancy providing wear free braking further reducing maintenance.
- Quick battery exchange for multi-shift work environment.

Features

The multi-directional FIORA side loading fork lift trucks are designed and built to carry both long and palletized material in narrow aisles.

The use of modern components and the latest technology make FIORA side lifts efficient and reliable even in the harshest operating conditions.

Space Savings

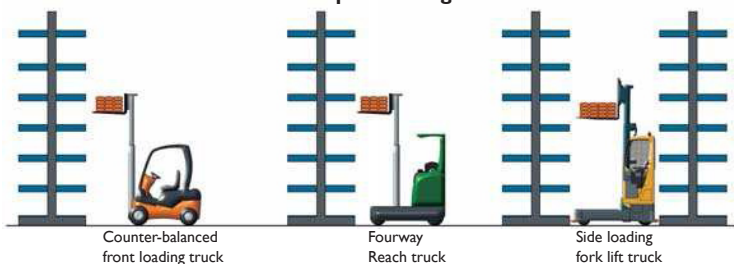

Driver friendly ergonomics

Two different cab options are available:

- ⇒ The F version with front facing operator position. Front facing in relationship to the load, affords excellent visibility in all directions;
- ⇒ The L version with longitudinal operator seating, minimizes the overall vehicle width to further optimize warehouse space utilization.

Both versions provide access to the cab from within the aisle. The operator gains access to the cab and may exit even when the vehicle is between the racks.

Driving comfort is ensured with a user friendly environment; a fully adjustable seat and easily accessible controls result in excellent vehicle control for the operator.

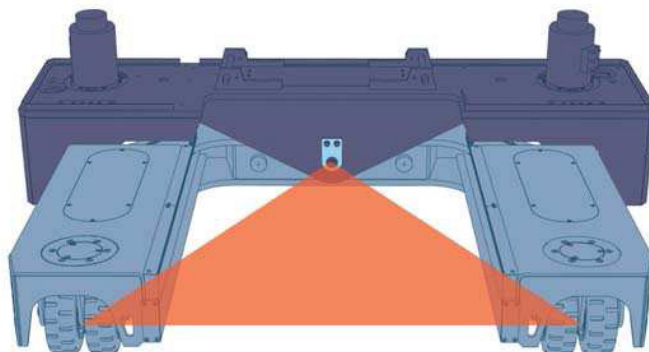

Multifunction proportional joystick

With the multifunction joystick all hydraulic functions are controlled with a single lever. The operator controls the hydraulics via a modern "fly by wire" concept open CAN-BUS technology. It is possible to control the machine with a simple movement of the hand. Buttons are used to select the various drive / steer modes as well as other functions.



The control centre features a large LCD which displays the actual wheel angles, the selected steering and travel modes of operation.

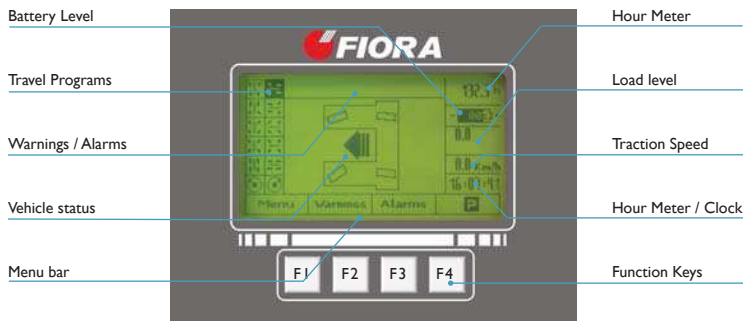

Multi-directional Travel

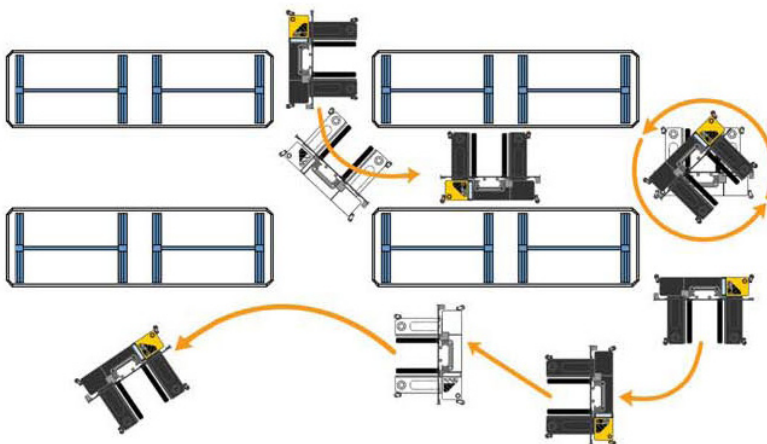

FIORA side lift trucks have a multi-directional steering system. The operator can choose from 12 different steering modes. It is possible to steer via the front wheels, the rear wheels or all four wheels simultaneously. This allows the truck to negotiate service aisles, travel diagonally or turn on its own axis.



Side facing cab

Maintenance

FIORA's on going commitment to employ the latest technology and advanced componentry makes it possible to reduce maintenance times and limit operating costs. The layout of the components has been designed to allow quick and easy maintenance access.



Optional

On request optional equipment such as: extended load bed, wide fork carriage with hydraulic adjustable fork spreader, individual fork load leveling, guide rollers, automatic shelf level selector, TV camera and monitor, integrated load weight cells and much much more are available - custom built to suit your application.



Professional Materials Handling Co., Inc.

6932 Hanging Moss Road

Orlando, FL - 32807

Tel (407) 677 - 0040

Fax (407) 678 - 0273

US distributor

email: info@pmh-co.com

www.pmh-co.com



Manufacturer reserves the right to make technical changes without prior notice.
Pictures and illustrations may show equipment with optional equipment.